



MIDWEST SCALE COMPANY

Administrative Office: 1327-7th Street - Rockford IL 61104

800-521-0857: Phone

800-870-0075 : FAX

Web: www.midwestscale.com

E-mail: sales@midwestscale.com

ISO/IEC 17025 CERT. #L02-93

Rockford, IL

Schaumburg, IL

Southern Wisconsin

Web Quote

We are pleased to offer the following for your consideration:

1 – Setra model Super II super high precision counting scale, rugged industrial design

- Capacity: choice up to 110 lb.
- Platform: (55lb and 110lb is 13”x 15” Stainless Steel)
(25lb and 35lb is 11.5”x 9.5” Stainless Steel)
- Computer interface: BI-DI RS 232
- Full numeric keypad
- High Accuracy, up to 5 times the weighing resolution of strain gauge

Price, **\$ 1495.00**

Notes:

Applicable sales tax not included

Freight prepaid and added to invoice

Terms: Net 30 days with credit approval, **VISA** and **Master Card** accepted

Sincerely,

Midwest Scale Company – Sales Department at (800) 521-0857 x16 or x18

Order Information – Fax to (800) 870-0075

Date:	
Customer Name:	PO# or Credit Card #:
Address:	
City, State, Zip:	
Phone Number:	
Accepted by:	

Super II™

high precision counting
and weighing scale

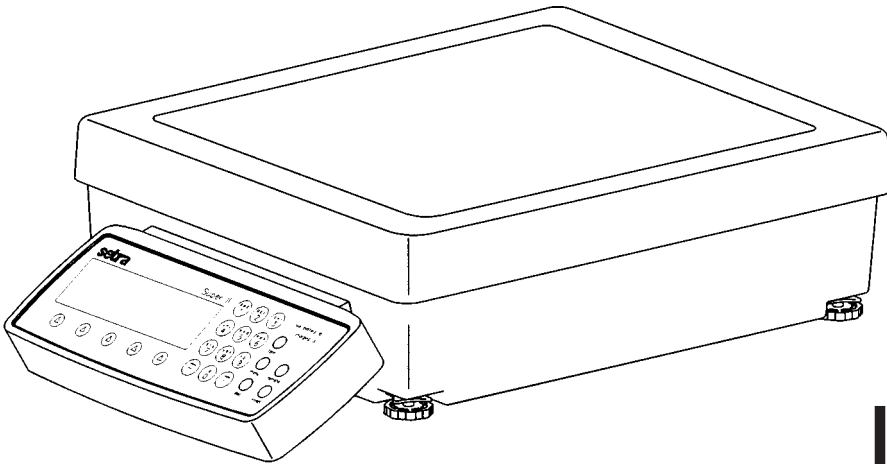

The Setra *Super II* combines incredible accuracy with easy-to-read, text prompts. With an internal database, bar code label making, set points and multiple base connectivity, the *Super II* is truly flexible. Input to the database can be entered with most computer keyboards or from the user friendly, cell phone style keypad. The scale menu that orders up a wide selection of features is easy to access, easy to navigate and easy to exit. Use it to build a log of daily transactions, customize display prompts, or set the optimal sample size for counting. Multiple ports keep you constantly connected...to a scanner, to a printer, to a computer, to your bulk weighing scale and to up to eight bases. *Super II* is unquestionably the superior choice in counting scales for all your receiving, kitting and inventory needs.

CAPACITY • READABILITY • ACCURACY

CAPACITY	STANDARD READABILITY	MAXIMUM READABILITY	LINEARITY ERROR
25 Kg	0.0005 Kg	0.00005 Kg	+/- 0.0005 Kg
30 Kg	0.0005 Kg	0.00005 Kg	+/- 0.0005 Kg
50 Kg	0.001 Kg	0.00005 Kg	+/- 0.001 Kg
55 lb	0.001 lb	0.0001 lb	+/- 0.001 lb
65 lb	0.001 lb	0.0001 lb	+/- 0.001 lb
110 lb	0.002 lb	0.0002 lb	+/- 0.002 lb

Advantages to Consider

- Paperless inventory with onboard database
- Checkweighing using set-points
- Sturdy, all metal construction for long life
- Graphic LCD to provide easily customized messages
- Macros offering simplified one-key operation
- Comm ports for simultaneous connection to a printer, a scanner, and a PC
- Speedy transaction processing and data logging
- Effortless keyboard data entry - optional QWERTY keyboard
- Portable operation - optional internal battery
- Multiple bases operated by one controller - remote scale option
- English & bar coded labels - optional Dymo Setra 300 printer

159 Swanson Road, Boxborough, MA 01719
978 263-1400 • fax 978 635-9551 • www.setra.com

Super II™ Specifications

Displayed Resolution: Selectable

Internal Resolution: 1 part in 1,000,000

Units of Measure: Pounds, kilograms, grams, ounces, pennyweights, troy ounces, carats, grains (user definable)

Display Update Rate: Selectable, five settings

Response Time: Two seconds (typical)

Counting Capacity: 10,000,000 pieces

Memory: 750 records including part number (23 characters), description (16 characters), count, average piece weight, tare, set points

Time and Date: Battery protected real time clock

Data Communications: Bi-Directional RS232 port for PC; OUT port for printer; IN port for scanner, KEYBOARD port for QWERTY PS/2® (6 pin mini DIN)

Selectable Baud Rate: 1200, 2400, 4800, 9600 (Com 1, 2, and 3)

Operating Temperatures: 40 °F to 100 °F (5 °C to 39 °C) 10 to 90% non-condensing

Power Adapters: Output 16VDC @ 550 mA, Input 120 VAC, 60 Hz or 230 VAC, 50 Hz

Dimensions:

Platform 13" W x 15" D (33 x 38 cm)

Controller 10.75" W x 4.38" D x 2.5" H (27 x 11 x 6 cm)

Overall 13" W x 19.38" x 4.5" H (33 x 48 11.5 cm)

Shipping Weight: 35.5 lb (16 Kg)

Certifications: UL, CSA, CE pending

Limited Warranty: Two years

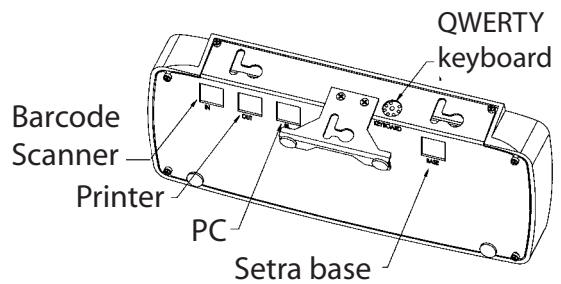
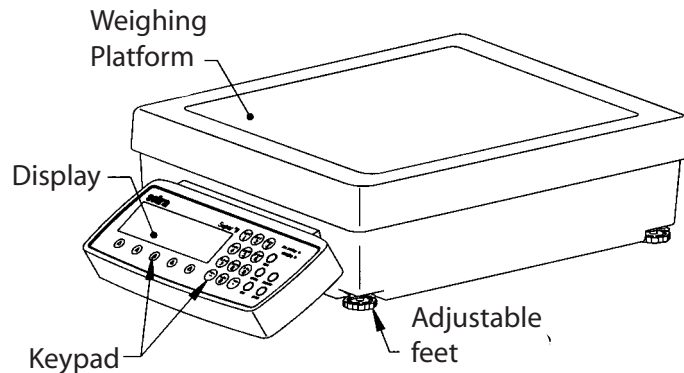

Controller Ports

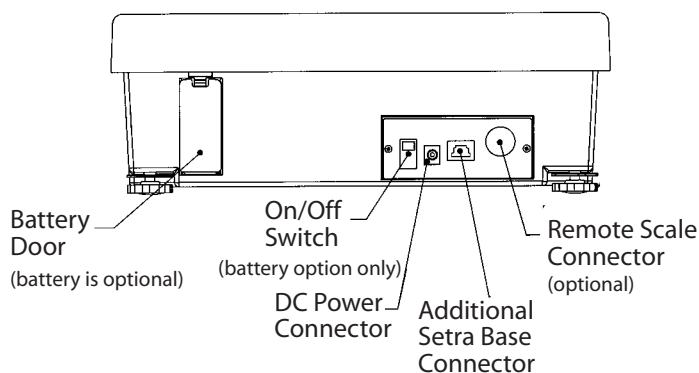

Setra Base - Rear View

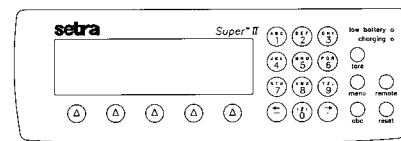

Keypad

